



*R53MM - Modular flow manifold,  
rapid bayonet fitting assembly with flow meter*



## *R53MM - Modular flow manifold, rapid bayonet fitting assembly with flow meter*

The modular manifolds **R53MM** DN32 with rapid bayonet push fit assembly and flow meters, have been designed for distribution of hot water for heating and cold water for air-conditioning. They have been designed to make installation easier and more rapid and the result is a highly flexible product with good aesthetics, ergonomics and functionality.

They are predominantly used in radiant panel or radiator systems where balancing controls and direct flow rate measurement in each circuit is required.

The innovative solution of a single module

The **R53MM** DN32 modules are manufactured from hot pressed brass. This gives the products superior mechanical properties, permitting increased dimensions for the internal flow passages thus reducing pressure losses and flow noise.

Each module contains a flow meter which accurately measures flow rates over a wide range (from 30 l/h to 300 l/h) which makes the unit suitable for a range of applications. Adjustment of the flow rate is by means of a micrometric lockshield valve with a mechanical memory stop and precision adjustment capability.

The modules **R53MM** should be used only for construction of a flow manifold and the water flow direction in each circuit should maintain the flow meter spring in compression.

with quick rapid bayonet fitting assembly allows the rapid construction of manifolds, without the need for tools and sealing gaskets. The manifolds have a high flow capacity and the number of outlets can be varied to suit the design of any installation.

The use of modular manifolds is revolutionary in this field and it allows stocks to be minimised in the warehouse since only two components are required to make manifolds of any size, unlike traditional one piece manifolds with fixed numbers of outlets.

The assembly of the modules is carried out manually and the hydraulic seal is provided by pre-assembled O-rings

The connection of the modular manifold **R53MM** to other components (valves, plugs, pipes, etc.) is made by using the two end modules **R53MT** DN32, which are available with 1" and 1"¼ female thread.

The threaded end has two flats for use with a spanner, to hold the manifold when tightening threaded components into the manifold end, so that the tightening stresses are not transmitted to the manifold modules.

The connection for the exit pipes is integral with the 18 base module and allows the use of distribution pipes of different dimensions and kinds, using suitable adaptors.

### Use

### Features

Max. working temperature 90°C  
Max. working pressure 1 Mpa (10 bar)  
Suitable for water for heating and air-conditioning  
Hot pressed body  
EP rings  
Manifold internal section DN32  
Flow meter, graduated scale 0.5 - 5 l/min

Lockshield adjustment valve with mechanical memory and protection cap  
Threaded ends available in 1" and 1"¼ sizes  
50 mm between centres of assembled modules  
Module with 18 base connection  
Protection packaging for each module

### Technical Data





*R53MM - Modular flow manifold,  
rapid bayonet fitting assembly with flow meter*

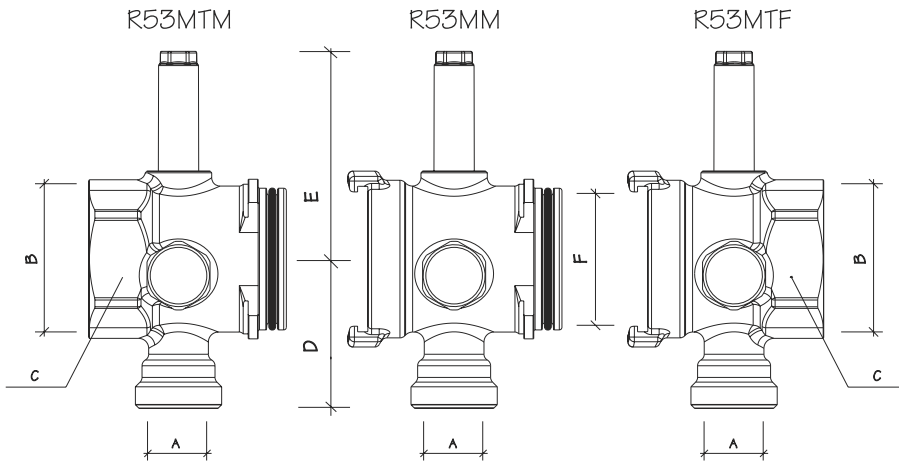

**Dimensions**

	A	B	C	D	E	F
R53MMY006	18	-	-	46	62	DN32
R53MTY006	18	1"	∅ 39	46	62	DN32
R53MTY007	18	1 1/4"	∅ 48	46	62	DN32

In order to install manifolds with the required number of connections, the rapid bayonet fitting modules **R53MM** are assembled manually. The assembly is very easy and it does not require the use of tools.

However it is necessary to check that the manifold bayonet features are clean and to lubricate the O-Ring with silicone grease.

In order to prevent damage to the O-Rings, we recommend that the modules are removed from the packaging one at a time before assembly.

The rapid assembly of single modules is carried out by presenting the male and female of the bayonet fittings with their vertical axes mutually rotated by 90 degrees. The two parts are gently pushed axially together until the seal is engaged in the housing and the shoulders on both parts are touching. One module is then



**Assembly**

rotated by 90 degrees so that the bayonet fixing engages. The bayonet assembly system does not require the use of tools. Tools must not be used to apply excessive twisting or crushing forces which might damage the manifold and cause a malfunction.

A pair of end modules **R53MT**, together with a suitable number of intermediate modules **R53MM**, are used to complete a distribution manifold with the required number of outlets.

In order to make a manifold with five outlets you should combine one pair of end modules **R53MT** with three intermediate modules **R53MM**. For a two port manifold, one pair of end modules **R53MT** are combined together without any intermediate modules.





## R53MM - Modular flow manifold, rapid bayonet fitting assembly with flow meter

The connection of the modular manifold to other components is made by using the two end modules **R53MT DN32**, which are available with 1" and 1 1/2" female thread. When gripping the end module to screw in other components, the wrench should only be applied to the flats provided for this purpose. After having installed the manifolds DN32 with the required number of connections, proceed with the assembly of the cabinet **R500** or **R501** or **R502** of appropriate dimensions, depending on the number of

manifold outlets and other accessories (zone valves, isolating ball valves, intermediate fittings etc.) The assembly should be carried out with the appropriate brackets **R588D** which allow the manifold to be mounted in the cabinet or, if required, directly to a wall. After having fixed the manifolds and the supply line connections, proceed with the pipe connection to the manifold outlets using 18 base Giacomini adaptors which are appropriate to the pipes in use.

### Assembly



When the required flow rate in each circuit is known, remove the lockshield valve protection caps and ensure that the circulating pump is working. Ensure that the isolating valves on the return manifold are fully open. Using tool **R588**, completely unscrew the mechanical memories and fully open the lockshield valves. Close the lockshield valves of each single module in turn until the required flow rates for each individual circuit is obtained. The flow rates are displayed on the graduated scales of the flow meters.

After the first adjustment, repeat the procedure a second time using very fine adjustments of the lockshield valves to give exactly the specified flow rate in each circuit. After the final adjustment, lock the mechanical memories and re-assemble the protection caps. If some specified flow rates can not be achieved, verify that the dimensioning of the circulating pump is correct and check that the manifold inlet is being supplied with the necessary pressure and flow rate.

### Adjustment

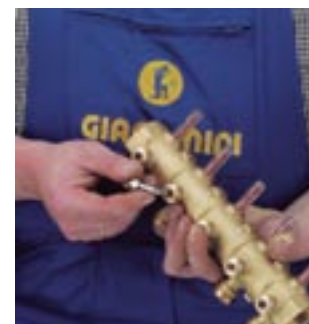

In normal use, the assembly of several modules in series involves negligible increase in pressure loss. When calculating pressure loss, use the graphs provided which give a very close approximation. The modular manifold **R53MM DN32**, which must be used only as a flow manifold, has no preferential direction for the water inlet and the pressure losses are not changed by supplying the manifold from either end. The pressure loss information in the following diagram refers to a single connection; for applications in heating systems, having flow and return manifolds, it is necessary to double the pressure loss shown in the diagram.

### Pressure losses

