



SIEMECA™

Mechanical Water Meter

WFU...
WFK...
WFW...

**Mechanical meters for measuring the consumption of cold or hot water.
Indication of cumulated consumption. Remote reading option.
Single-jet dry runner without remote reading output.**

Use

To acquire the water consumption in:

- Domestic water systems of residential or non-residential buildings
- Water supply systems of any type
- Multi-family houses, office and administrative buildings

Typical users are:

- Private building owners and property associations
- Building maintenance companies and housing estate agents

Functions

- Acquisition of water consumption
- Cumulation of the consumption values
- Display of the consumption values

Type summary

Meters without a remote reading output

Max. water temperature [°C]	Mounting length [mm]	Q_N [m ³ /h]	Connection sizes (ISO 228)	Magnetic Shielding	Type reference of meter
30	110	1.5	G 1	No	WFU10.110-1
30	80	1.5	G ¾	Yes	WFK20.D080
30	110	1.5	G ¾	Yes	WFK20.D110
30	130	2.5	G 1	Yes	WFK20.E130
90	110	1.5	G 1	No	WFU20.110-1
90	80	1.5	G ¾	Yes	WFW20.D080
90	110	1.5	G ¾	Yes	WFW20.D110
90	130	2.5	G 1	Yes	WFW20.E130

Meters with a remote reading output (NAMUR)

Max. water temperature [°C]	Mounting length [mm]	Q_N [m ³ /h]	Connection sizes (ISO 228)	Magnetic Shielding	Type reference of meter
30	110	1.5	G 1	No	WFU12.110-1
30	80	1.5	G ¾	Yes	WFK23.D080
30	110	1.5	G ¾	Yes	WFK23.D110
30	130	2.5	G 1	Yes	WFK23.E130*
90	110	1.5	G 1	No	WFU22.110-1
90	80	1.5	G ¾	Yes	WFW23.D080
90	110	1.5	G ¾	Yes	WFW23.D110
90	110	2.5	G 1	Yes	WFW23.E130*

Meters with a remote reading output (Reed)

Max. water temperature [°C]	Mounting length [mm]	Q_N [m ³ /h]	Connection sizes (ISO 228)	Magnetic Shielding	Type reference of meter
30	110	1.5	G 1	No	WFU17.110-1
30	80	1.5	G ¾	Yes	WFK24.D080
30	110	1.5	G ¾	Yes	WFK24.D110
30	130	2.5	G 1	Yes	WFK24.E130*
90	110	1.5	G 1	No	WFU27.110-1
90	80	1.5	G ¾	Yes	WFW24.D080
90	110	1.5	G ¾	Yes	WFW24.D110
90	130	2.5	G 1	Yes	WFW24.E130

Accessories

Spacers for universal meters	Mounting length [mm] / Connection sizes	Type reference
	80 / ¾"	WFZ.R80
	110 / ¾"	WFZ.R110
	110 / 1"	WFZ.R110-1
	130 / 1"	WFZ.R130

Other accessories	Description	Type reference
	Two fittings for universal meter ¾"	WFZ.R2
	Two fittings for universal meter 1"	WFZ.R2-1
	Cover for magnetic protection of meters with a remote reading output	WFZ.M

Ordering

When ordering, please give type references according to "Type summary".
The meter is supplied with two flat seals and a metal seal with a sealing wire.
Fittings and spacer are not included in the standard delivery. They must be ordered as separate items.

Technical design

Direct reading

The flow of water is measured with a hydraulic impeller. The flow rate value is transferred to a mechanical totalizer via a magnetic clutch. The meter has

- a totalizer (maximum value 99.999,999 m³), which gives the current reading (for US: 99,999,999 US-gallons; for GB: 99,999,999 imperial gallons)
- a totalizer (1 revolution = 1 liter), which shows the current consumption in liters (for US: 1 revolution = 1 US-gallon; for GB: 1 revolution = 1 imperial gallon)
- a flow check

Remote reading output

The types of meters with a remote reading output contain a Reed contact with or without a NAMUR circuitry. This contact is used by the meter to deliver the acquired flow values as pulse variables. One pulse represents a volume of 10 liters (or gallons) of water.

The NAMUR circuitry detects open-circuits or short-circuits by evaluating the resistance values.

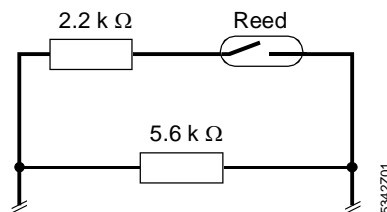

NAMUR circuitry

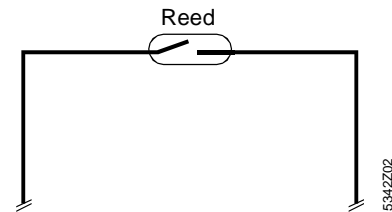

Reed contact without NAMUR circuitry

Mechanical design

Basic design and totalizer

The water meter is comprised of flow measuring section, which houses the impeller and the totalizer. It is designed as a compact unit; flow measuring section and totalizer form one unit.

The body of the flow measuring section is made of nickel-plated brass. It houses the measuring chamber with the single-jet impeller. The inlet has a strainer to retain larger dirt particles.

The flow measuring section carries the totalizer, which is a dry runner. It is protected by a transparent plastic cover. The water meter indicates the actual consumption with an 8-digit totalizer. It has an indicator for the current water consumption and a rotating wheel for the indication of flow.

The version with the remote reading output has a cable of 1.4 m which is ready connected to the side of the meter.

Direct connection

The universal meter for direct connection has a flow measuring section with two externally threaded connections. Fittings are used to mount it directly into the piping (refer to "Accessories")

The totalizer can be swivelled through 360°.

Accessories

Spacer

Spacer which can be used in place of the meter for flushing the piping before mounting the meter, etc.

Fittings

The fittings are made of nickel-plated brass. They consist of insert, nut and flat seals and are used for mounting the spacer or the water meter.

Cover for magnetic protection

To prevent tampering with meters having a remote reading output, a protective cover can be fitted. This cover protects the pulse contact against magnetic effects.

The cover is placed on the totalizer module and then sealed. It has a window to show the reading and a hole for the cable.

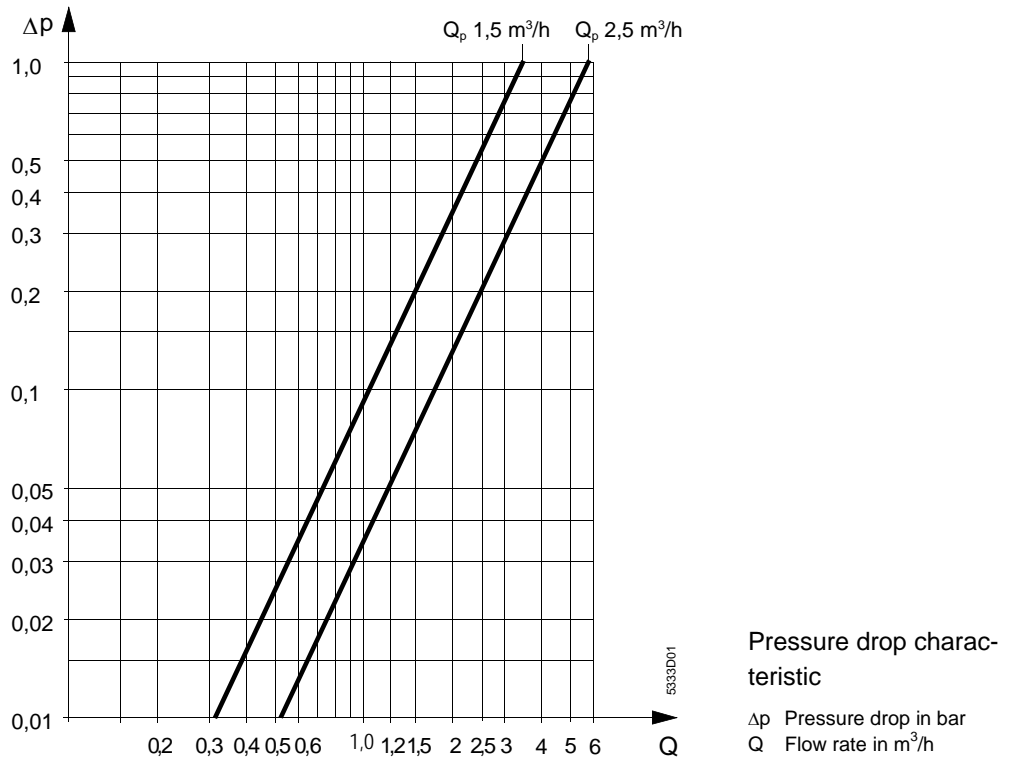

Mounting notes

- The local regulations for the use of water meters (mounting, sealing, etc.) must be complied with
- The water meter should preferably be mounted between two shutoff valves. To facilitate reading and service work, it should be easily accessible
- If the water meter is only used at the time of commissioning, it is possible to fit the spacer first
- Prior to mounting the water meter, the piping must be thoroughly flushed. For this purpose, fit the spacer
- The flow measuring section can be mounted horizontally or vertically. For higher metrological classes, the position must be taken into consideration, however
- The direction of flow (indicated by an arrow on the body) must be observed
- Before the flow enters the measuring section, there should be a straight piece of piping of at least 35 mm
- The totalizer should be placed in a position where it is easy to read (horizontal)
- After mounting, the respective test pressure must be applied to the plant

Operating notes

For operation, recalibration and replacement of the water meter, the local regulations must be observed.

Technical data

Measurement accuracy class (DIN ISO 4064/1)			
Horizontally	B		
Vertically	A		
Unit	m ³		
Flow rates	1,5 m ³ /h	2,5 m ³ /h	
Min. flow rate Q_{\min} H / V	30 l/h / 60 l/h	50 l/h / 100 l/h	
Lower limit of flow rate Q_t	120 l/h	200 l/h	
Nominal flow rate Q_{nenn}	1500 l/h	2500 l/h	
Max. flow rate Q_{\max}	3000 l/h	5000 l/h	
Starting flow, horizontal	5 l/h	8 l/h	
Max. perm. operating pressure	10 bar		
Range of use of flow measuring section	1...90 °C		
Behavior in the event of excessive flow			
Flow rate = 2 q_{\max}	linear		
Flow rate > 2 q_{\max}	constant		
Perm. ambient temperature			
Transport und storage	5...55 °C		
Operation	max. 55 °C		
Degree of protection	IP 64		
Pulse output for remote reading			
Pulse valency	10 l/pulse for US: 10 US-gallon/pulse for GB: 10 imperial gallon/pulse		
Current rating	100 mA		
Pulse length at Q_N	approx. 0.6 s		
Connections and weight	1.5 m ³ /h	1.5 m ³ /h	2.5 m ³ /h
Pipe connection (inlet and outlet)	¾"	¾"	1"
Mounting length	80 mm	110 mm	130 mm
Weight	0.4 kg	0.45 kg	0.6 kg

Dimensions

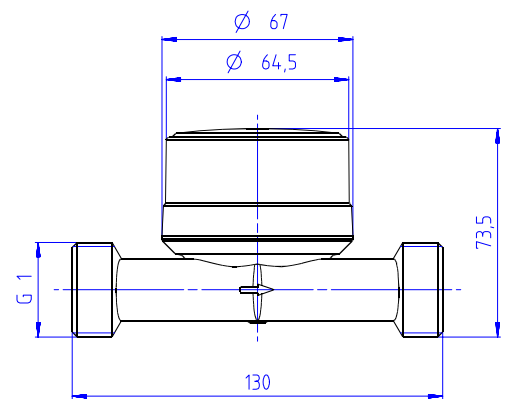
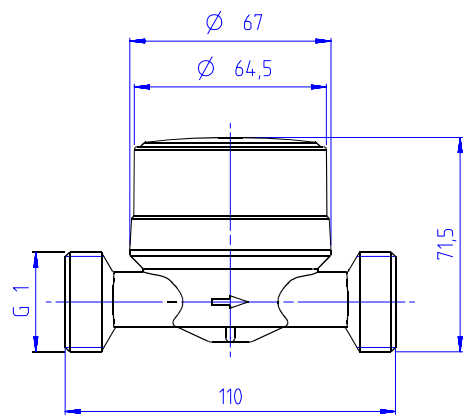
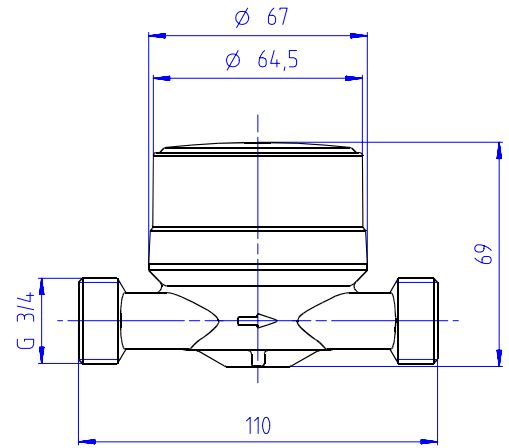
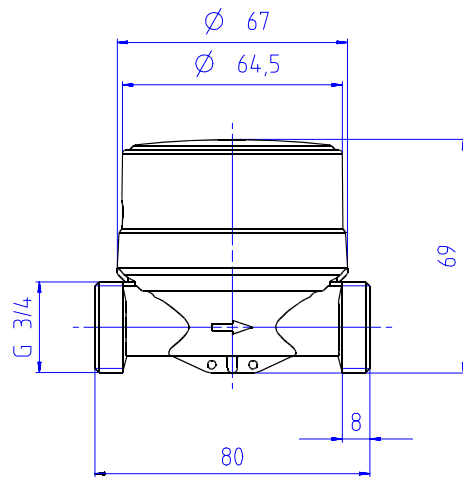

This Data Sheet only contains general descriptions and technical features which, in the case of specific applications, may not necessarily apply, or which may change due to further development of the product. Technical details and features are binding only if explicitly agreed upon at the time of contract closure.

©1999 Siemens Building Technologies AG
Subject to alterations